

Above Ground Stormwater Retention and Detention Tanks



Authorised dealer and installer:



JUST TANKS



WWW.JUSTTANKS.CO.NZ

30 YEARS OF PROVEN TANK MANUFACTURING

Devan Plastics has been in the business of making tanks for over 30 years. If there is anything that time has taught us it is that our customers do not compromise when it comes to quality.

DESIGNED FOR EASY SPECIFICATION

Devan's stormBANK tanks adhere to Water tank standard AS/NZS4766 specifications and boast generic seismic and wind restraint systems designed for New Zealand's toughest regions. PS1 Documents for restraints are provided with all stormBANK tanks, ensuring compliance with seismic zones 1, 2, and 3, along with very high wind zones.

DESIGNED TO BE SUSTAINABLE

Devan's stormBANK tanks are crafted from the highest quality polyethylene, specifically chosen for its compatibility with our advanced moulding technique, ensuring extended durability and trouble-free performance. The material is certified to meet Water tank standard AS/NZS4766:2006, Drinking water contact standard AS/NZS4020:2005, and Food contact standard AS/NZS 2070, making it suitable for potable water applications.

Polyethylene, known for its resistance to the weather and corrosion, is UV stabilized to withstand New Zealand's challenging environmental conditions. Our manufacturing process is designed to produce zero polyethylene waste, and the product is fully recyclable. When the tank reaches the end of its useful life, customers can return it to us for recycling into other enduring products.

Code	Product	Height	Width	Depth	Weight
TT01S	1,000L stormBANK	2,000mm	870mm	870mm	30 kg
TT02P	2,000L stormBANK kit	2,000mm	1,765mm	870mm	60 kg
TT03P	3,000L stormBANK kit	2,000mm	2,650mm	870mm	90 kg
TT04P	4,000L stormBANK kit	2,000mm	3,550mm	870mm	120 kg
TT05P	5,000L stormBANK kit	2,000mm	4,420mm	870mm	150kg
SPARK	Restraint pole kit - 1 per 1,000L	2500mm	50mm	50mm	30 kg
SPAB50	50mm Multi-tank Connection Kit - stormBANK	-	-	-	-

Devan Colours

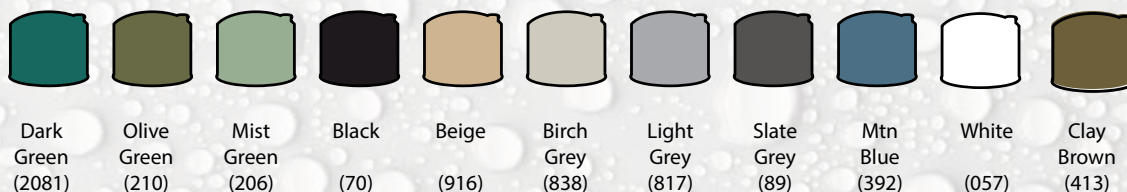

Please note that the colours represented above are the best match possible within screen and printing variations.

FEATURES AND BENEFITS OF STORMBANK

In situations where space is limited, stormBANK tanks prove to be the perfect solution for both existing and new homes. Specifically engineered to remain inconspicuous, these tanks were designed with a focus on effortless handling from the outset.



NARROW - ONLY 870MM WIDE!

Devan's stormBANK tanks are designed to maximise space utilisation, thanks to their modular design the tanks can be discreetly installed in a variety of spaces.



DESIGNED FOR EASY INSTALLATION

Devan's stormBANK tanks prioritises effortless installation. Weighing just 30kg each, the 1,000L tanks are designed for easy handling, and the included 50mm coupling device simplifies the joining process.



LARGE BRASS OUTLETS

Devan's stormBANK tanks features our renowned brass 50mm BSP outlets, with two in each tank. This larger outlet aids in balancing when utilizing or connecting multiple tanks.

Additionally, there are two 15mm outlets designed for garden taps. Installing extra 25mm outlets for orifice overflow points or garden taps is a straightforward process, facilitated by our separately sold easy plumb fittings.

CAN BE BURIED

Devan's range of stormBANK tanks can be partially buried up to 500mm to reduce the overall height to only 1500mm



DESIGNED FOR FUTURE EXPANSION

Devan's stormBANK tank range is designed to accommodate future expansion, allowing flexibility as funds permit or when expanding your property.

Adding more capacity is a hassle-free process – simply prepare the ground and use one of the connection devices to integrate additional 1,000L tanks at a later date.

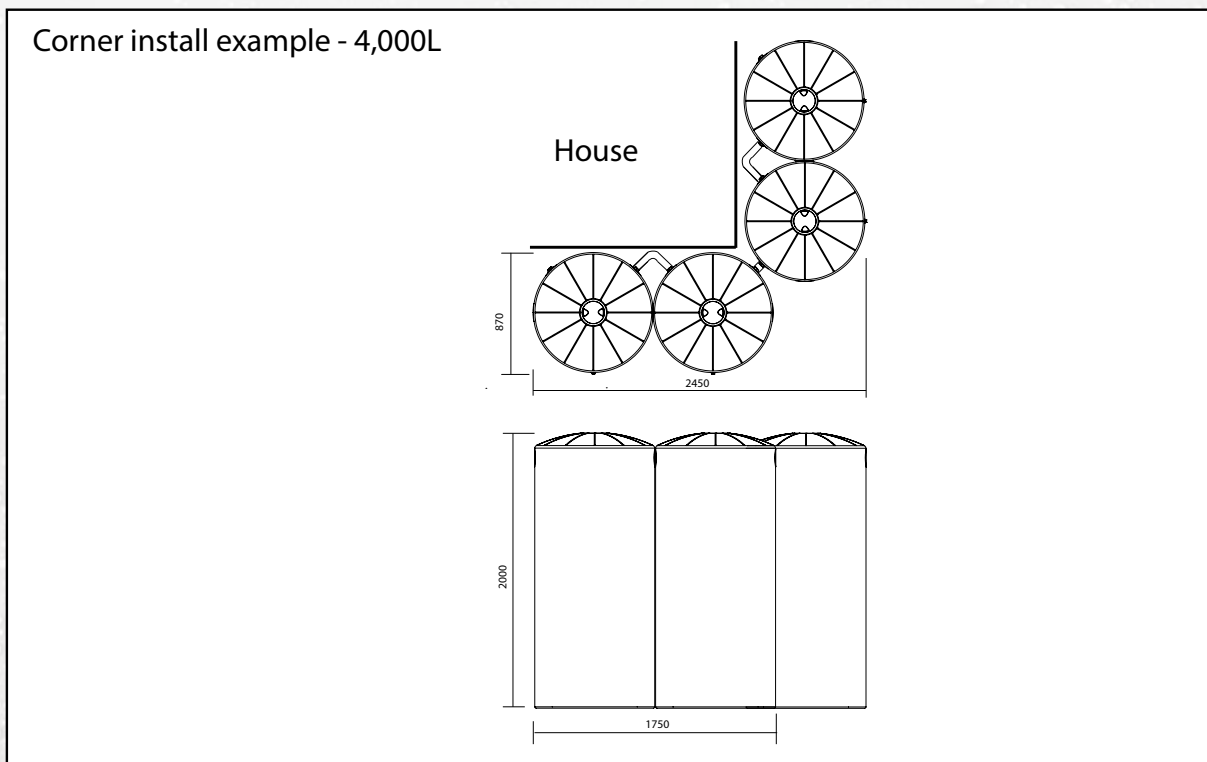
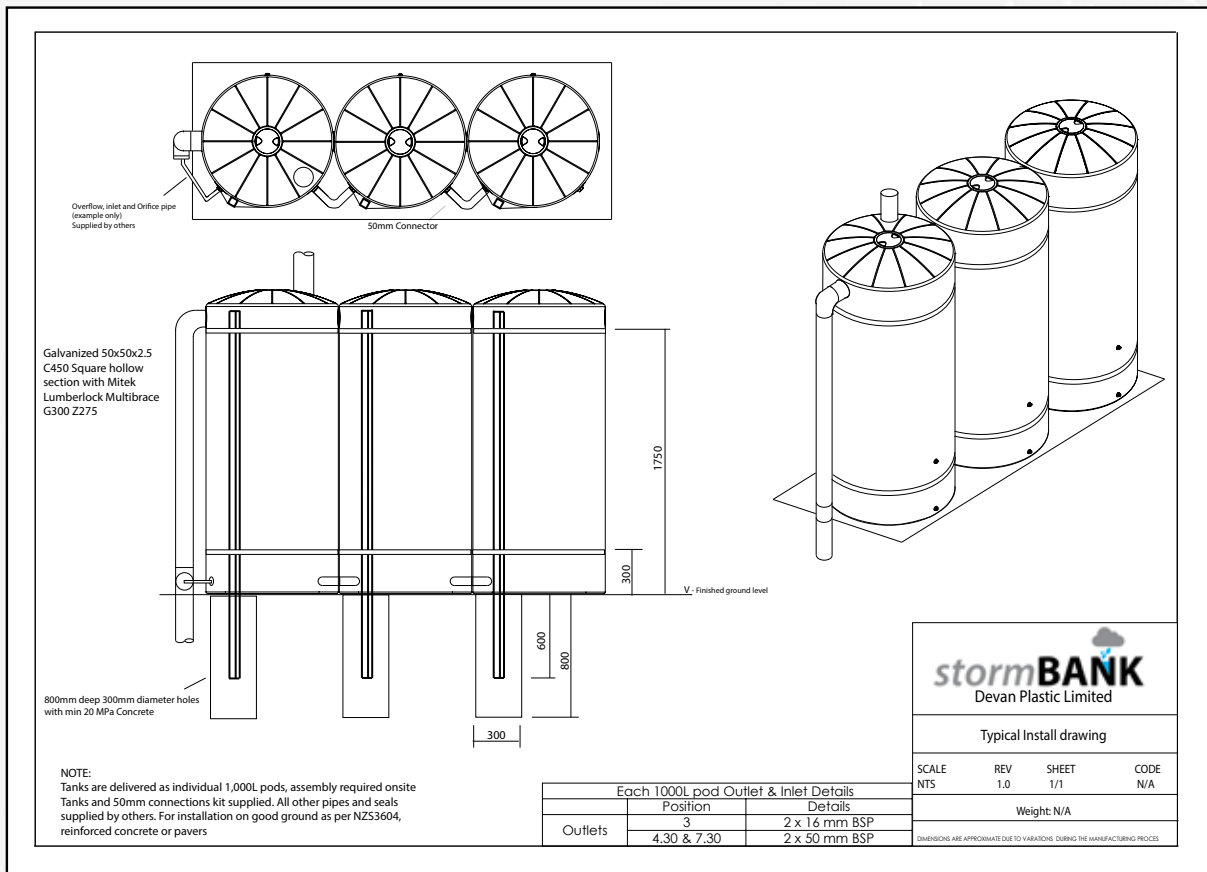

JUST TANKS

24 Hannigan Drive, St Johns, Auckland

Contact Mike Marsden, General Manager

021 560075 mike@justtanks.co.nz



JUST TANKS